

Meyn RM1200 rehanger

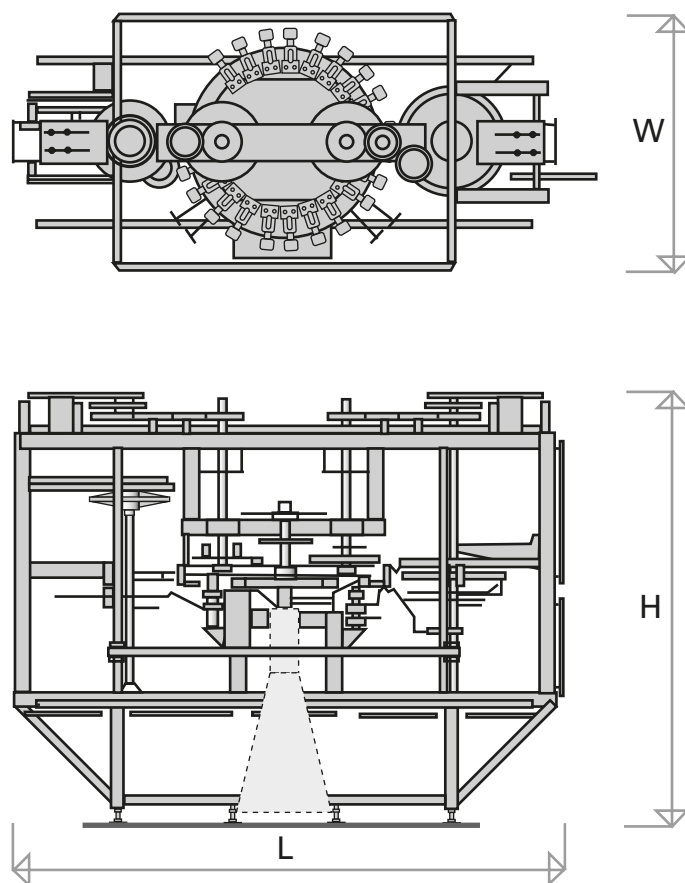

Capacity	BPH	12,000
Griller weight	kg	1.0-3.5
Length (L)	mm	3,560
Width (W)	mm	1,652
Height (H)	mm	2,850
Weight	kg	1,900
Electric power installed	kW	1x 0.37
Compressed air connection	BSP	1/2"
Compressed air consumption	m ³ /hr	0.6
Options:		
Weighing unit	kg	200
Hock cutter	kW	1.0
Shank cutter	kW	1.0

Head office:

Meyn Food Processing Technology B.V.
 Westeinde 6, 1511 MA Oostzaan (Amsterdam)
 P.O. Box 16, 1510 AA Oostzaan
 The Netherlands

T: +31 (0)20 2045 000
F: +31 (0)20 2045 001
I: www.meyn.com

MEYN

Poultry Processing Solutions

Meyn RM1200 rehanger

- Excellent transfer rate, no back up personnel required.
- Can be applied in virtually any combination of lines.
- Maximum capacity 12,000 birds per hour, independent of shackle pitch.
- Very accurate weighing, independent of product weight range.
- Sophisticated control unit, automatic start up, reduction of downtime.

